

1. Application

This specification applies to the coin-type Capacitor of FORECON(electric double layer capacitor), which FORECON super capacitor technology CO.,LTD.manufactures, and which supplies to the customer specified in the cover page of this document.

Please read these applications and approved them.

2. Part number system

SC DK 5R5 155 H

① ② ③ ④ ⑤

① SUPER CAPACITOR

② Series Name

③ Rated Voltage : 5.5Vdc

④ Capacitance : 105– 1.5F

⑤ Lead Type : V - Vertical Type,
H - Horizontal Type,

3. Nominal Specifications

No.	Characteristics	
3-1	Operating temperature range	-25 °C to +70 °C
3-2	Maximum Operating Voltage	5.5 V .DC
3-3	Nominal Cap. Range	1.0F to 1.5F
3-4	Capacitance Range	-20% ~ 80 %

4. Inner structure chart

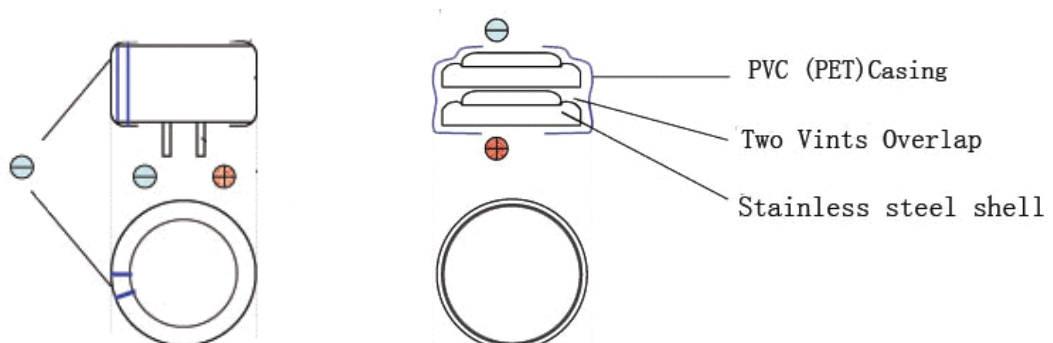

5. Construction And Dimension

V type

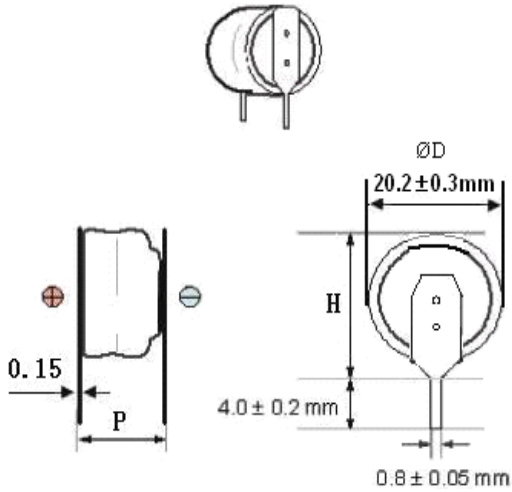

H type

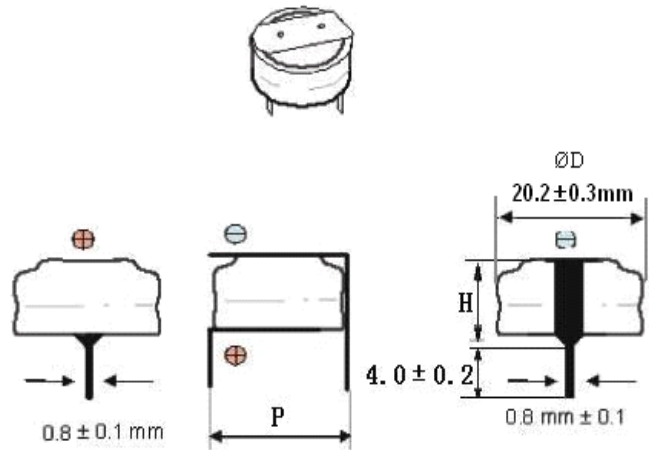

C type

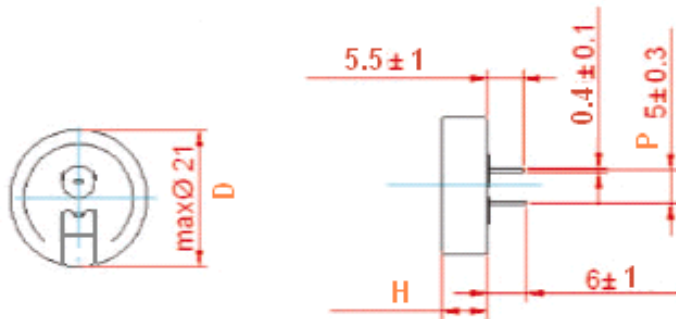

Part NO.	Operating Voltage (V)	CAPACITANCE (F)	ESR (Ω @1KHZ)	LEAKAGE CURRENT ()	V type (mm) D*H*P	H type (mm) D*H*P	C type (mm) D*H*P
SCDK5R5105	5.5VDC	1.0	≤ 30	20 MAX	20.2*21*4.0	20.2*5.0*20	21*7.5*5
SCDK5R5155	5.5VDC	1.5	≤ 30	30 MAX	20.2*21*5.5	20.2*6.5*20	/

6. Specifications and Test Method

ITEM		SPECIFICATION		TEST CONDITION
CAPACITANCE		1.0 ~ 1.5F		Refer to characteristics measuring method
CAPACITANCE TOLERANCE		-20% ~+80%		Refer to characteristics measuring method
EQUIV. SERIES. RES. (ESR)		Refer to standard ratings		FRE. : 1KHZ, 1mA
LEAKAGE CURRENT (24h)		Refer to standard ratings		VOLTAGE : 5.0Vdc TO SEE MEASURE METHOD RESISTANCE : 100Ω
TEMPERATURE CHARACTERISTICS	CAPACITANCE	Step 2	± 30% OF INI. VAL	<p>Measurements shall be made at each of the temperatures specified above after the capacitor has reached thermal stability</p> <p>Step 1: +20±2°C Step 2: -25±2°C</p> <p>Step 3: +20±2°C Step 4: +70±2°C</p> <p>Step 5: +20±2°C</p> <p>*) Thermal stability</p> <p>The condition of thermal stability is judged to be reached when two readings of ESR taken at an interval of not less than 5 min do not differ by an amount greater than which can be attributed to the measuring apparatus.</p>
	ESR		4 TIMES OF INI. VAL	
	LC		SPEC. VALUE	
	CAPACITANCE	Step 4	± 30% OF INI. VAL	
	ESR		SPEC. VALUE	
	LC		SPEC. VALUE	
	CAPACITANCE	Step 5	± 30% OF INI. VAL	
	ESR		SPEC. VALUE	
	LC		SPEC. VALUE	
LEAD STRENGTH		LEAD TERMINAL SHALL NOT BE		LOAD 1kg , 10± 1 SEC
LEAD BEND STRENGTH		SEPARATED		LOAD: 1kg , ANGLE 90° ,1CYCLE
VIBRATION RESISTANCE	CAPACITANCE	SPEC. VALUE		<p>AMPLITUDE: 1.5 mm</p> <p>FREQUENCY: 10~ 55HZ</p> <p>DIRECTION:X,Y,Z 3DIRECTIONS</p> <p>TEST TIME: 6 HOURS</p>
	ESR	SPEC. VALUE		
	LC(24h)	SPEC. VALUE		
	APPEARANCE	NO MARKED DEFECT		
HUMIDITY RESISTANCE	CAPACITANCE	90%↑ OF SPEC. VAL		<p>TEMP:40± 2°C , HUMIDITY:90 ~ 95%RH, TEST TIME:250±10HOURS , NO VOLTAGE APPLIED</p> <p>The specimen shall then remain under standard atmospheric condition for recovery for a period adequate for the attainment of temperature stability, with 12 to 24hr.</p>
	ESR	1.2TIMES ↓ OF SPE. V		
	LC(24h)	1.2TIMES ↓ OF SPE. V		
	APPEARANCE	NO MARKED DEFECT		
SOLDER ABILITY	CAPACITANCE	SPEC. VALUE		<p>SOLDER TEMP:260± 5°C IMMERSION TIME:10± 0.5SEC DIP LENGTH : TO 1.6mm FROMBOTTOM OF THE BODY</p>
	ESR	SPEC. VALUE		
	LC(24h)	SPEC. VALUE		
	APPEARANCE	NO MARKED DEFECT		
SELF DISCHARGE CHARACTERISTICS	CAPACITANCE	MORE THAN 4.2V	CHARGING CONDITION	VOLTAGE : 5.0V RESISTANCE : 10Ω CHARGE TIME : 24h
			NEGLIGENCE CONDITION	24HOURS NEGLIGENCE TEMP. : LESS THAN 25°C HUMIDITY : LESS THAN 70%RH
ENDURANCE	CAPACITANCE		±30% OF SPEC. VAL	<p>TEMP:70± 2°C</p> <p>TEST TIME : 1,000± 24HOURS</p> <p>APPLIED VOLTAGE : 5.5 Vdc</p>
	ESR		4TIMES ↓ OF SPE. V	
	LC(24h)		3TIMES ↓ OF SPE. V	
	APPEARANCE		NO MARKED DEFECT	

7. Measuring Method Of Characteristics

1) . CAPACITANCE

一、 Constant-Discharging Method

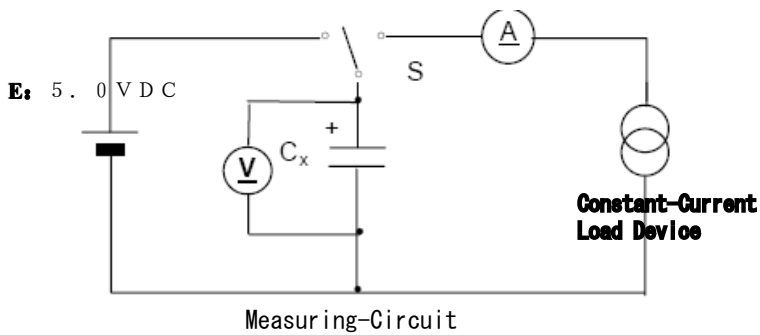

\textcircled{A}	DC Ammeter
\textcircled{V}	DC Voltmeter
S	Switch
C_x	Test Sample
E:	DC Constant-voltage Power

二、 Test methods

- ◎ Set DC constant-voltage as 5.0V.
- ◎ Set constant-current of this device as 1mA
- ◎ Switch S to constant-current and charge 30 min under rating voltage.
- ◎ When charging is over, switch S to constant-current discharge device under constant-current 1mA.

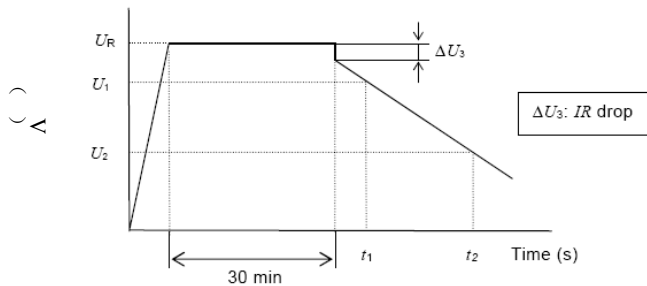

Charging and discharging Curve

- ◎ Calculate capacitance using the following formula:

$$C = \frac{I \times (t_2 - t_1)}{U_1 - U_2}$$

C Capacitance (F) ;

I : Discharging current (A) ;

U1: Starting Voltage 4.0 (V) ;

U2: Ending Voltage 2.0 (V) ;

t1: The time while the tab-voltage of capacitor reach to starting voltage U1.

t2: The time while the tab-voltage of capacitor reach to ending voltage U2.

2). Internal Impedance

Measure by alternating method with Frequency 1kHz. Base voltage : 0V

3). Leakage Current

After test sample is charged in the circuit shown in the following Fig. by listed voltage (E) and listed protective resistance (R) for listed time in following Table, measure the voltage (V) between tabs of protective resistance (R).

Then calculate Leakage Current (I) by following formula.

$$I = V/R \times 10^3 \text{ (mA)}$$

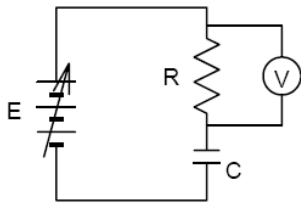

Leakage Current Measuring Circuit

Charging voltage (E)	Protective resistance (R)	Charging Time (T)
5.0V	100ohm	24h

4). Equivalent series resistance (ESR)

ESR is calculated from following expression by using a 1 kHz oscillator, applying an AC current of 10 mA and measuring the voltage (Vc) between both ends of the capacitor.

Equivalent series resistance : $ESR = \frac{V_c}{0.01} \text{ (}\Omega\text{)}$

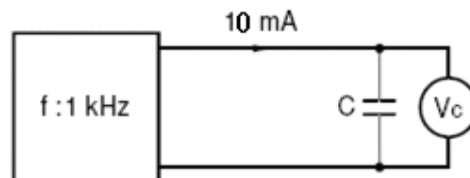

5) .Self-discharge characteristic

The self-discharge characteristic is measured by charging a voltage of 5.0 VDC (charge protection resistance: 0 Ω) according to the capacitor polarity for 24 hours, then releasing between the pins for 24 hours and measuring the pin-to-pin voltage.

This test should be carried out in an environment with an ambient temperature of 25°C or below and relative humidity of 70% RH or below.

8. Package specifications

PRODUCT	QUANTITY			SIZE		WEIGHT (kg)	TYPE
	Tray (pcs)	Bag (pcs)	Box (pcs)	Tray (mm)	Box (mm)		
SCDK5R5105H	100	/	2200	380*280*21	400x300x290	10	BULK
SCDK5R5105V	100	/	2200	380*280*21	400x300x290	10	BULK
SCDK5R5155H	100	/	2000	380*280*21	400x300x290	10	BULK
SCDK5R5155V	100	/	2000	380*280*21	400x300x290	10	BULK
SCDK5R5105C	100	/	1800	380*280*21	400x300x290	16.3	BULK

9 .Cautions For Use

1) .Voltage

If apply more than rated voltage,the interior of the capacitor will occur chemosynthesis.The gas of solicitation will let the capacitor leak out and broken.

2) .Operating temperature and condition

①The endurance of capacitor is arosed of temp.Generally,
the endurance can twice over longer when temp.reduce 10 Degree.So using the capacitor at normal temperature.

② If using the capacitor above the allow range, it may not only shorten the useful life of capacitor, it may also cause serious breakage (such as electrolyte leak out). So when check the operating temp, not should check the condition temp, and inner temp. also should check the radiation of another exothermic component and the itself's caloric by concussive electric urrent. caution: then not allowed in the back of capacitor placed exothermic component.

3) .Concussive electric current:

The internal impedance of super capacitor is higher than any other electrolytic capacitors, so it is more easy exothermic when impingement by concussive electric current. when the temperature of the capacitors raise, the Inner of capacitors will has vertiginous electric current which arose the internal impedance, and the capacitor's sustentation will be difficult, so it is set a allowed range to avoid temperature's raise: below 3 celsius degree when measure the surface of capacitors.

4) .Series super capacitors:

Assume the following possibility: the voltage of series super capacitor is unbalanced (to insure the voltage of the capacitors in the allowed range), if the capacitor's balance is broken, the capacitors will be over loading. in order to avoid that situation, it can let one parallel esistance In the both side of capacitors to partake the voltage, to ensure leakage current won't affect another capacitors.

5) .Thermal shock when soldering:

The deterioration of the capacitor shall be caused when it is excess thermal shock, The gas tightness will be bereaved. It will be leakage because the internal pressure is raise.

- ① If the solder iron touch the scarfweld, the capacitor's scarfweld will melt down or broken.
- ② Set the soldering temp. and time consult the current reference drawing.
- ③ When soldering with the old iron, don't touch the top of the Capacitors. Please do quickly as soon as possible when touch the lead terminal.
- ④ Do not over 150°C when use the equipment such as ultraviolet oven preheat the capacitors and hardening by bond. If over 150°C, The wrappage of capacitor will broken, And the seal at top will be shrink.
- ⑤ Don't conduct reflow soldering by infrared heating or air heating.

6) .Cleaning of circuit board

Can cleaning the capacitors with immerge it in the suit solvent or use ultrasonic,within 5minute,and below 60°C.

The circuit board must be cleaning drastically and airing.

7) . The electrical source of capacitors is DC,don't use to filter wave for commutating.

8) .Product can store two years under normal temperatures and room pressure.We can ensure the quality one year ender normal using,if the wrong usage cause the products damage,is not in the quality control scope.

9) . Storage Please store supercapacitor in following condition ;

Temp. : 15 ~ 35°C, Humidity : 45 ~ 75% RH, Non-dust

10) . Please don't disassemble supercapacitor . Because its electrolyte is organic solvent.